

# Medialon Showmaster Hardware Manual

User Reference

## Trademark Information

Medialon is a trademark of 7thSense Design Ltd. Product or company names that mentioned in 7thSense Design Ltd publications are tradenames or trademarks of their respective owners, and such trademarks may also be registered in their respective countries.

## Copyright Information

All Rights Reserved. This document is copyrighted © by 7thSense Design Ltd and shall not be reproduced or copied without express written authorization from 7thSense Design Ltd.

The information in this document is subject to change without notice. 7thSense Design Ltd assumes no responsibility for errors, and/or omissions contained in this information.

## Document Revision

Date	Document edition	Software version	Revision details	Author/Editor
May 2020	M569-1	Medialon Manager 6.7 Medialon Showmaster Editor 2.7.0		Eric Cantrell Andie Davidson (ed)
August 2022	M569-2	Medialon Manager 7 Medialon Showmaster Editor 2.7.0	Reformatted	Andie Davidson (ed)
June 2023	M569-3	Medialon Manager 7.1	Editor software deprecated, superseded by Manager	Dominic Turpin
October 2023	M569-4	Medialon Manager 7.1	Recommended maximum device limits added	Andie Davidson (ed)
January 2024	M569-5	Medialon Manager 7.1	Additions on using Manager on a Showmaster	Andie Davidson (ed)

## M569-5

---

# Contents

---

<b>1 Manager on Showmaster Pro and LE .....</b>	<b>3</b>
1.1 Upgrading Showmaster Pro and LE units.....	3
1.2 Remote Connections to Showmaster units.....	3
1.3 Related user guides.....	4
<b>2 About this Manual .....</b>	<b>5</b>
2.1 Prerequisites.....	5
2.2 Objective of this Manual.....	5
<b>3 Showmaster Overview.....</b>	<b>6</b>
3.1 Embedded Show Controllers.....	6
3.1.1 Showmaster Architecture .....	9
3.1.2 Medialon Showmaster Modes .....	10
3.2 Showmaster Mini Description.....	10
3.2.1 Contents of the Package.....	10
3.2.2 Getting Started .....	10
3.2.3 Front Panel Controls .....	11
3.2.4 Side Panel.....	11
3.2.5 Mounting .....	11
3.2.6 Technical Specifications .....	11
3.3 Showmaster LE Description .....	13
3.3.1 Contents of the Package.....	13
3.3.2 Getting Started .....	13
3.3.3 Front Panel Controls .....	14
3.3.4 Rear Panel.....	15
3.3.5 Rack Mount.....	17
3.3.6 Technical Specifications .....	18
3.4 Showmaster Pro Description.....	21
3.4.1 Contents of the Package.....	21
3.4.2 First Start.....	21
3.4.3 Front Panel Controls .....	21
3.4.4 Rear Panel.....	24
3.4.5 Rack Mount.....	28
3.4.6 Technical Specifications .....	29

3.5 Showmaster Go Description.....	33
3.5.1 Contents of the Package.....	33
3.5.2 Getting Started .....	33
3.5.3 Front Panel.....	33
3.5.4 Rear Panel .....	34
3.5.5 Mounting .....	35
3.5.6 Technical Specifications .....	35
3.5.7 Environment.....	36
3.5.8 Maintenance.....	37
3.6 Disposal Information: All Showmaster Devices.....	37
<b>4 Showmaster Maintenance.....</b>	<b>39</b>
4.1 Showmaster Troubleshooting.....	39
<b>Contact Us .....</b>	<b>40</b>

# 1 Manager on Showmaster Pro and LE

---

Showmaster LE and Pro units have previously used Showmaster Editor software. They now run Medialon Manager 7, in line with Showmaster Go and Mini. Any Showmaster can now be addressed as a full Windows PC using remote access (VNC or Remote Desktop Connection). Showmaster LE and Pro can also be addressed using the Manager Web Interface.

**This manual edition relates to Medialon Manager 7.1 running on Showmaster devices and no longer running Showmaster Editor.**

For Showmaster Editor, please see the previous edition:  
[M569-2 Showmaster Hardware Manual-Editor](#).

## 1.1 Upgrading Showmaster Pro and LE units

---

Showmaster devices running Manager require more data storage; older units can be upgraded.

Existing Showmaster LE and Pro units may be upgraded from Showmaster V2, requiring return to 7thSense for replacement larger SSD and OS update, and installation of Manager 7.1.

Please note that projects created in Editor (from version 2.7) must be manually updated before being loaded in Manager 7.1 on upgraded Showmaster Pro and LE. This is important to avoid corrupting projects written in older versions of Manager.

- Please contact our sales team at [info@7thsense.one](mailto:info@7thsense.one) for more information, and to enquire about compatibility of your Showmaster hardware with Medialon Manager 7.1
- [M866 Showmaster Upgrade Checklist](#)  
This is your FAQ and reference when upgrading Showmaster Pro and LE to Manager 7.

## 1.2 Remote Connections to Showmaster units

---

All models of Showmaster can be addressed using remote access software. We recommend VNC, Windows RDC, or TeamViewer. If using TeamViewer, turn off logging to avoid filling the hard drive.

- See guide **M865 Showmaster Remote Access**  
(using Manager on a Showmaster device via VNC or RDC)

Showmaster Pro and LE upgraded to Manager 7 can also be addressed via Medialon Web Interface.

- See guide **M816 Medialon Manager Web Interface** (controlling Showmaster LE or Pro over IP)

All these and other Medialon user guides are available on the 7thSense user portal:  
[https://portal.7thsense.one/online-help/medialon\\_library.html](https://portal.7thsense.one/online-help/medialon_library.html)

## 1.3 Related user guides

---

- **M515** Medialon Control Systems Manual (Medialon Manager V7 user guide)
- **M868** Medialon Manager 7.1 Release Notes

# 2 About this Manual

---

This manual is written for professional users: show technicians, freelancers and end user technicians who are responsible for installing and running Medialon Showmaster show controllers in live events or permanent installations.

## Important: please read

- M562 Medialon Safety Instructions for installation, use and service
- M561 End User's License Agreement for Medialon Software and Plug-Ins. Warranty Terms and Conditions for Medialon Hardware

## 2.1 Prerequisites

---

This manual assumes the following prerequisites:

- Proficiency using Windows interface
- General knowledge of computer hardware
- General knowledge of control protocols: DMX 512, MIDI, Serial, Timecode
- General knowledge in audio-visual: Video, Video processing, Audio, Lighting, Machinery
- General knowledge in show structure

## 2.2 Objective of this Manual

---

After reading this manual, you will be able to:

- Describe the features of Medialon show control hardware
- Set up hardware required for a Show Control installation using Medialon show control hardware

# 3 Showmaster Overview

## 3.1 Embedded Show Controllers

Medialon Control System brings the power of Medialon Manager, award-winning Show Control software, in a rugged and compact hardware design.



**i** The Showmaster range includes products that are managed in different ways. All models run Medialon Manager on the Showmaster hardware. Programming is done directly on the Showmaster Mini or Showmaster Go hardware. This is a key difference. Programming can be done directly on the Showmaster LE and Pro as well as offline (without the ability to run or debug the project) using Medialon Manager set in the appropriate mode.

	Programming Software	Number of Timelines	Number of Web Panel Connections	Number of Devices
<b>Showmaster Mini</b>	Medialon Manager for Showmaster Mini	0	1	20, upgradable in batches of 10 to max of 50
<b>Showmaster LE</b>	Medialon Manager for Showmaster LE	1	3	Recommended max 150
<b>Showmaster Pro</b>	Medialon Manager for Showmaster Pro	Unlimited	10	Recommended max 300
<b>Showmaster Go</b>	Medialon Manager Lite or Pro	1 or Unlimited	2 or 10, upgradable in batches of 10	Recommended max 150

Showmaster LE and Showmaster Pro use a run-time version of Medialon Manager software. A timeline show is created by connecting a computer / laptop to Showmaster via Ethernet, authoring the project either directly on the Showmaster using a remote connection or offline, and then transferring the finalised project (see also guide [M865-1 Showmaster Remote Access.pdf](#)).





Medialon Showmaster benefits from the extensive Medialon device plug-in library for connectivity with a wide range of audio-visual equipment.

Showmaster projects can be created directly on the Showmaster via a connection through either RDP or TeamViewer, as well as offline using Medialon Manager. In the latter case, the resulting project file must be deployed to the Showmaster's hard drive either manually or through the Showmaster's web interface (Pro or LE models only).

## Showmaster Mini

Showmaster Mini is a capable and flexible device is suited to simple AV control applications and installation types. Its ruggedized, fanless, small form factor makes it easy to mount where AV racks are not suitable. Showmaster Mini carries a reduced-feature version of Medialon Manager show control software, making it a low-cost solution that still carries the power, flexibility, and ease of use Medialon is known for. Designed for less demanding applications, it starts with a 20-device limitation, expandable in 10-device batches up to a max of 50 devices. This AV device controller runs Medialon Manager V6 and V7 for Showmaster Mini for step-based tasks only.



The connectors for Showmaster Mini are all on the front of the unit, as it is meant to be mounted vertically on a DIN rail. It includes two Serial ports, four USB 3.0 ports, two HDMI ports (for Local Panels and programming), two 10/100/1000 Base-T Ethernet ports, and the power button.

Showmaster Mini runs Windows 10 IoT Enterprise LTSC and includes Medialon Manager for Showmaster Mini software for programming and show execution.

## Showmaster LE

Showmaster LE is an all-in-one Embedded Show Controller fitted with all necessary show protocol interfaces. It controls and synchronizes dimmers, lighting desks, video projectors, video servers, sound processors etc. Showmaster LE also provides digital I/O.

Its editing software, Medialon Manager 7.1, embeds most of the features of our award-winning technology such as devices synchronization and logical programming as well as real time testing. It allows programming of one show at a time, up to 3 Web Panels but does not support 3rd party extension interfaces.

Medialon Showmaster LE is a 1 U, full 19" rack-mountable machine; the front panel consists of function buttons and status LEDs.



The rear panel hosts two 10/100/1000 Base-T Ethernet interfaces, digital I/O connections, serial ports, a DMX port, and MIDI ports.



Medialon Showmaster LE operates on an embedded operating system (OS) and is programmed with Medialon Manager 7.1 software.

## Showmaster Pro

Showmaster Pro is an all-in-one embedded Show Controller fitted with all necessary show protocol interfaces. It controls and synchronizes dimmers, lighting desks, video projectors, video servers, sound processors etc. Showmaster Pro also provides digital I/O and balanced timecode input/output with video reference.

Its editing software, Medialon Manager 7.1, embeds most of the features of our award-winning technology such as devices synchronization and logical programming as well as real time testing. It supports multiple timeline, 3rd party interfaces, up to 10 Web Panels and signal recording.

Medialon Showmaster Pro is a 2U, full 19" rack-mountable machine; the front panel consists of an LCD display, function buttons and status LEDs. (Mk 2 illustrated).



The rear panel hosts two 10/100/1000 Base-T Ethernet interfaces, digital I/O, serial ports, DMX ports, MIDI ports and timecode input and output ports.



Medialon Showmaster Pro operates on an embedded operating system (OS) and is programmed with Medialon Manager 7.1 software.

## Showmaster Go

Showmaster Go is the top of the line Medialon show control product, running Medialon Manager V6 and V7 software and MAS Pro Dante software on the same compact, ruggedized hardware. It is intended to be mounted on things that move: ride vehicles, parade floats, tour buses, trams, show barges, etc.

It can be mounted in a 1U rack mount (three can fit side by side in 1U of rack space), or it can be mounted in a shock mount carrier for high vibration/high shock environments. The front panel includes the power button, a USB 2.0 type A connector, and a USB 3.0 type C connector.



The rear panel has four DisplayPort outputs (for Local Panels), a GPIO port with 3 software-configurable channels of Input or Output, two 10/100/1000 Base-T Ethernet ports, and two USB 2.0 type A ports.



Showmaster Go runs Windows 10 IoT Enterprise LTSC and includes Medialon Manager (Lite or Pro, depending on licensing) and MAS Pro software (licensed for 16, 32 or 64 channels of Dante output).

### 3.1.1 Showmaster Architecture

The remainder of this section is specific to the Showmaster Pro and Showmaster LE architecture, since it differs from Medialon Manager, documented elsewhere in this manual. The following sections only apply to Showmaster LE and Showmaster Pro.

### 3.1.2 Medialon Showmaster Modes

Showmaster LE/Pro switches between different modes to run and to program.

#### Running or Normal Mode

This is the default mode of Medialon Showmaster LE/Pro. At startup, Showmaster LE/Pro uses its locally connected resources and runs the show.

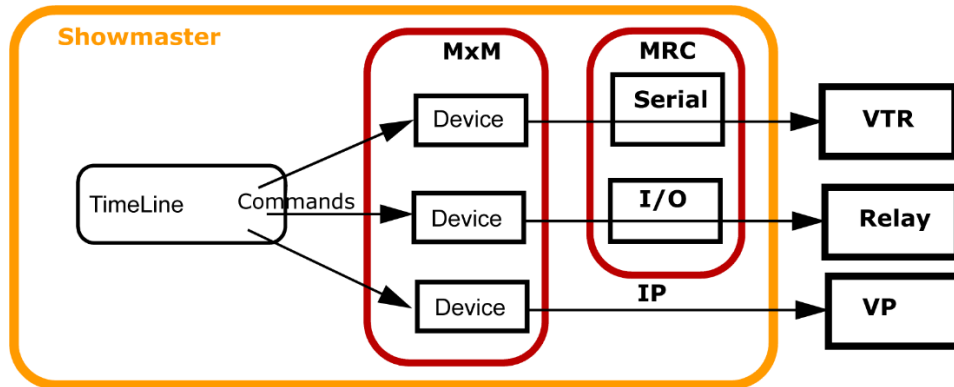

- Device Commands are executed when the Timeline runs.
- The Devices send command orders using a Medialon plug-in (MxM) through the appropriate resources (MRC) to connected machines.

#### Programming Mode

Programming is done in Stop mode using either an offline version of Medialon Manager that is set to the appropriate Showmaster model's mode, or directly on the device via a remote connection.

## 3.2 Showmaster Mini Description

### 3.2.1 Contents of the Package

The Medialon Showmaster Mini Package includes:

- Medialon Showmaster Mini
- Power adaptor

### 3.2.2 Getting Started

Showmaster Mini runs a version of Medialon Manager, and programming can be done directly on the hardware.

### 3.2.3 Front Panel Controls



#### Power button

🔌 Press to power on Showmaster Mini. The orange LED indicates the power state.

- 2 × Serial, COM 1 and COM 2
- 4 × USB 3.0
- 2 × RJ45 10/100/1000 base-T Ethernet
- 2 × HDMI UHD

### 3.2.4 Side Panel

The image below shows the side panel of Medialon Showmaster Mini. This has the Phoenix DC power connector and 3.5 mm mini-jack sockets for line out and mic in.



### 3.2.5 Mounting

The rear panel has 3 screw points for attaching a DIN-rail bracket for vertical mounting. Alternatively, the unit can be wall mounted using two correct brackets, attached to left and right sides at the lower two screw points on each side.

### 3.2.6 Technical Specifications

USB ports	4 × USB 3.0
Serial ports	2 × RS232
Video output	2 × HDMI UHD
Audio	1 × mic in, 1 × line out, 3.5 mm mini jack
Ethernet	2 × 10/100/1000 base-T
Storage	238 GB SSD

## Showmaster Overview

Power connection	12-28 VDC 60 W (3 pin Phoenix connector)
Power consumption	7.6 W typical, 19 W max.
Mounting options	DIN-rail/Wall Mount
Dimensions (W × D × H)	158 mm × 114 mm × 53.5 mm (6-1/4" × 4-1/2" × 2-1/8")
Weight	1.2 kg (2.65 lbs)

Technical specifications are subject to change without prior notice. Please check [www.medialon.com](http://www.medialon.com) for the latest information.

## Environmental Specifications

### Operating Temperature

- With industrial-grade SSD/mSATA: -30 ~ 70 °C (22 ~ 158 °F), with airflow rate = 0.7 m/sec
- With 2.5-inch hard disk: 0 ~ 45 °C (32 ~ 113 °F), with airflow rate = 0.7 m/sec

### Relative Humidity

- 95% @ 40 °C (non-condensing)

### Storage Temperature

- -40 ~ 85 °C (-40 ~ 185 °F)

### Vibration Tolerance

- When the system is equipped with an SSD/mSATA: 3 Grms, IEC 60068-2-64, random, 5 ~ 500 Hz, 1 hr/axis, (x, y, z) 3 axes

### Shock Tolerance

- When the system is equipped with an SSD/mSATA: 30 G, IEC 60068-2-27, half sine, 11 ms duration

### Safety Certification

- UL, CB, CCC, BSMI

### EMC Certification

- CE, FCC, CCC, BSMI

### Federal Communications Commission (FCC Statement)

This equipment has been tested and found to comply with the limits for a Class B digital device, pursuant to part 15 of the FCC Rules. These limits are designed to provide reasonable protection against harmful interference in residential installations. This equipment generates, uses, and can

radiate radio frequency energy and, if not installed and used in accordance with the instructions, may cause harmful interference to radio communications. However, there is no guarantee that interference will not occur in a particular installation. If this equipment does cause harmful interference to radio or television reception, which can be determined by turning the equipment off and on, users are encouraged to try to correct the interference by one or more of the following measures:

- Reorient or relocate the receiving antenna.
- Increase the separation between the equipment and receiver.
- Connect the equipment into an outlet on a circuit different from that to which the receiver is connected.
- Consult your dealer or an experienced radio/TV technician for help.

For further technical information, please refer to the Advantech ARK-1220L user manual.

## 3.3 Showmaster LE Description

---

### 3.3.1 Contents of the Package

The Medialon Showmaster LE Package includes:

- Medialon Showmaster LE
- Power adaptor

### 3.3.2 Getting Started

Medialon Showmaster LE is designed as a stand-alone Show Controller.

Showmaster LE does not need a keyboard, mouse or screen to work.



Connect the power supply and press and hold the front  button to start Showmaster LE.

### 3.3.3 Front Panel Controls

#### Button Functions

##### A button

Not used.

##### B button

Not Used.

##### Power button

 Press this button to power on Showmaster.

Press this button to power off (soft power) Medialon Showmaster.

#### LED Status Messages

Four LEDs give a quick overview of the main status of Medialon Showmaster.

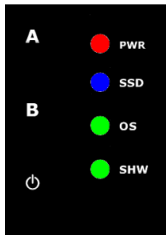

##### **PWR: Power LED**

This LED lights red when Showmaster is powered on.

##### **SSD: SSD LED**

This LED blinks blue when Showmaster is reading or writing to its internal storage.

















##### **OS: Showmaster LED**

This LED indicates the current status of Medialon Showmaster.

##### **SHW: Project LED**

This LED indicates the current status of the Medialon Showmaster Project.



Status	OS	SHW
Default (Not Ready) State	OFF 	OFF 
Showmaster Starting Up / Shutting Down	Blink 	OFF 
Showmaster Ready (OS)	ON 	OFF 
Showmaster Project Starting	ON 	Blink 
Showmaster in Running Mode	ON 	ON 
Showmaster in Programming Mode	ON 	Blink Slow 
License Missing		Alternate Blink 
IP Address Conflict Detected	Pulse x3 	ON 

### 3.3.4 Rear Panel

The image below shows the rear panel of Medialon Showmaster LE.



- [LAN] RJ45 Ethernet LAN connectors (10/100/1000 Base-T)
- [USB]: Not used (\*)
- [Serial 1] Serial Port 1: Serial RS232 port
- [Serial 2] Serial Port 2: Serial RS232 port
- [MIDI] MIDI Port: MIDI Input and Output
- [DMX512] DMX Port: DMX512 Output
- [Relay Outputs] Digital Output Port: 4 relays 24 V 1 A Max
- [Digital Inputs] Digital Input Port: 4 contact closure input detection max 10 kΩ
- [POWER] Power Connector 12 VDC 5 A. [See Power section for details.](#)

(\*) USB bottom port may be used for maintenance purposes (such as image updates/restoration), top port is not used.

## Digital Input/Output Port Wiring

### Digital Input Connector

Showmaster LE has four digital (contact closure) inputs.

Digital Inputs are connected to Showmaster LE via terminal block connectors.

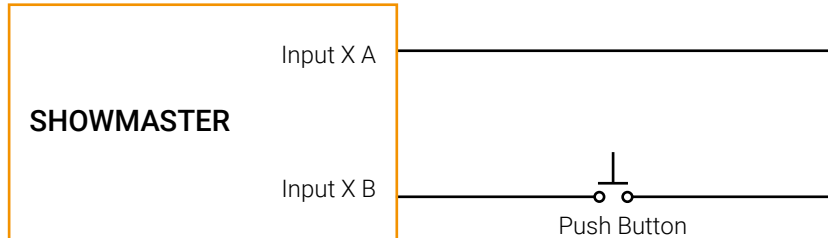

### Relay Output Connector

Showmaster LE has four relays. Relay outputs are connected to Showmaster LE via 4 terminal block connectors.

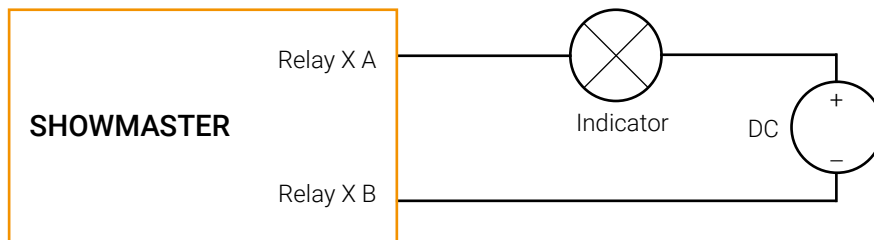

### MIDI Connection

Medialon Showmaster LE is provided with MIDI Input and Output port.

#### Pin Connection

- | Pin | Connection                 |
|-----|----------------------------|
| 1   | NC                         |
| 2   | NC                         |
| 3   | Cable shield (output only) |
| 4   | +5 V DC (source)           |
| 5   | MIDI Data (sink)           |

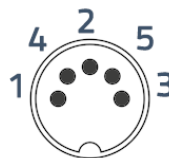

## DMX Connection

Medialon Showmaster LE is provided with a DMX 512 output.

### Pin Connection

1	Ground
2	Data -
3	Data +
4	NC
5	NC



## Serial Connection

Medialon Showmaster LE is provided with 2 serial ports.

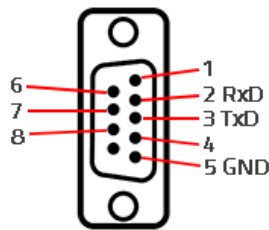

Showmaster LE is configured with DTE serial ports. Use a crossover (null modem) cable when you want to connect to a computer.

### 3.3.5 Rack Mount

**WARNING** – The unit is intended to be rack-mounted as per applicable requirements so no imbalance likely to occur to the internal components. Adequate clearance for airflow should be provided on both sides so ambient temperature does not exceed the limit.

- Please refer to document: **M562 Medialon Safety Instructions** for installation, use and service.

## Installation

**NOTE** You need a #2 Phillips screwdriver for rack mount installation. Complete the following steps to mount devices in a rack:

- Remove the rack mount kit from the shipping carton. The kit contains two L-shaped mounting brackets and four sink-head screws.
- Using a Phillips screwdriver, attach the mounting brackets to the sides of the device using four sink-head screws.
- Using a Phillips screwdriver, mount the device in the rack using four rack-mounting screws.

## 3.3.6 Technical Specifications

### Network Connection

- Number: 2
- Connector: RJ45 female
- Interface: 10/100/1000 Mbps (1000 Base-T)
- Protocol: TCP/IP
- Addressing: Static IP or DHCP

### USB Connections

- Number: 2
- Connector: USB slave socket
- Interface: USB 2.0
- USB Top Port: Not Used
- USB Bottom Port: May be used for maintenance purposes (such as image updates/restoration)

### Serial Interfaces

- Number: 2
- Connector: 9-pin D-type Male
- Format: RS-232

### Digital Interfaces

Isolated Inputs:

- Number: 4
- Mode: Contact closure
- Connector: terminal block

Relay Outputs:

- Number: 4 Relays
- Contact Type: Dry Contact
- Max. Switching Voltage: 24 V DC
- Max. Switching Current: 1 A
- Connector: terminal block

## DMX Interface

- *Number:* 1 DMX512 Output
- *Connector:* XLR 5 pin – type Female

## MIDI Interface

1 MIDI Output / 1 MIDI Input

- *Connector:* MIDI DIN 5 pin – type Male

## Physical

- *Size Rack Mount (W × D × H):* 18.75 × 10.25 × 1.75" (476 × 260 × 44.5 mm)
- *Size Stand-alone (W × D × H):* 17.38 × 10.25 × 1.75" (441 × 260 × 44.5 mm)
- *Weight:* 11 lbs (5 kg)
- *Operating Temperature:* 32°F – 104°F (0°C – 40°C)
- *Storage Temperature:* –4°F – 185°F (–20°C – 85°C)
- *Operating Humidity:* 10 – 80% RH Non-condensing
- *Storage Humidity:* 5 – 90% RH Non-condensing
- *Operating Altitude:* sea level to 2000 metres.

## Power

- External Power Adapter EDACPOWER ELEC
- Model EA10683N-120
- AC Input 100-240 V – 2.0 A, 50-60 Hz
- DC Output 12 V DC 5 A
- Connector: DC-Jack

## Approvals

- FCC 47 CFR Part 15 Subpart B
- ICES-003 Canada
- EN 55032
- IEC 61000-3-2 and IEC 61000-3-3
- EN 55024
- IEC-61000-4-2 and IEC-61000-4-3 and IEC-61000-4-4 and IEC-61000-4-5 and IEC-61000-4-6 and IEC- 61000-4-11

- IEC/EN/UL 62368-1
- CSA C22.2#62368-1
- IEC 60950-1

### **Federal Communications Commission (FCC Statement)**

This equipment has been tested and found to comply with the limits for a class A digital device, pursuant to Part 15 of the FCC rules. These limits are designed to provide reasonable protection against harmful interference when the equipment is operated in a commercial environment. This equipment generates, uses, and can radiate radio frequency energy, and if not installed and used in accordance with the instruction manual, may cause harmful interference to radio communications. Operation of this equipment in a residential area may cause harmful interference, in which case the user will be responsible for correcting any interference at their own expense

Changes or modifications not expressly approved by the party responsible for compliance could void the user's authority to operate the equipment

FCC responsible:

7thSense Design Ltd  
4207 Vineland Rd.  
Suite M1  
Orlando, FL 32811  
USA

T: +1 407 505 5200

### **EMC notices**

EN55032/CISPR32 Class A MME (MultiMedia Equipment)

**Warning:** This equipment is compliant with Class A of CISPR 32. In a residential environment this equipment may cause radio interference.

GB/T 9254 Class A ITE (Information Technology Equipment)

**Warning:** This is a Class A product. In a domestic environment this product may cause radio interference in which case the user may be required to take adequate measures.

### **Accessories**

- *Included:* Power adaptor, rack mount brackets

## 3.4 Showmaster Pro Description

### 3.4.1 Contents of the Package

The Medialon Showmaster Pro Package includes:

- Medialon Showmaster Pro
- Power Supply cord

### 3.4.2 First Start

Medialon Showmaster Pro is designed as a stand-alone Show Controller.



Showmaster Pro does not need a keyboard, mouse or screen to work. Rear power switch must be set on all the time.

Connect the power supply and press and hold the front  button to start the Showmaster. The front panel LCD displays the start-up message.

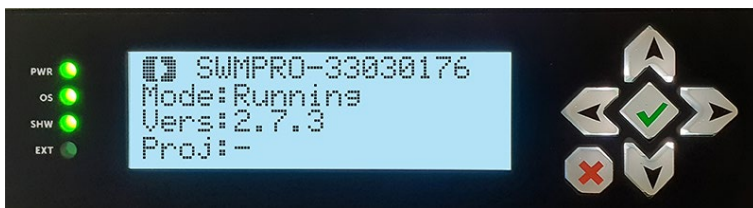

### 3.4.3 Front Panel Controls

Use the buttons to scroll through Showmaster's status information.

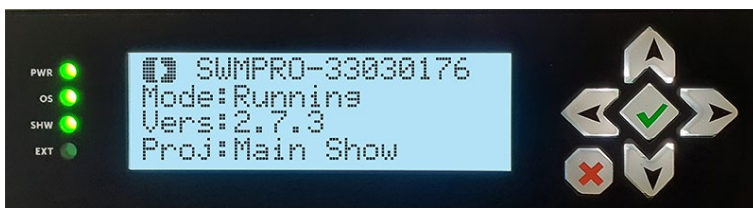

## Button Pad Functions

### OK button



- Hold this button for more than 1 second to power on Showmaster Pro.
- Hold this button for more than 4 seconds while the Showmaster Pro is powered on to reset it.

### Cancel button



- Hold this button for more than 4 seconds to power off (soft power) Showmaster Pro.

### Up arrow



- Scrolls display up.
- Holding this button for more than 1 second scrolls the display to the home position when the button is released.

### Down arrow



- Scrolls display down.

### Left arrow



- Not in use.

### Right arrow



- Not in use.



## LCD Display Messages

Each time an arrow button is pressed, the next line of information is displayed.

1. [Name] Showmaster's user-defined Name
2. [Mode] Showmaster's current mode:
  - *Starting Up*: Showmaster Pro is starting up (from power-on until Showmaster Pro is ready)
  - *Initializing*: Key hardware features have been read, waiting for software to boot up
  - *Starting Software*: Manager software is not yet running
  - *Running*: Showmaster is running.
  - *Programming*: a project is being edited or tested
  - *Debugging*: Manager is in debug mode, a user is editing the project
  - *License Missing*: the unit's license file is missing from disk
  - *Shutting Down*: Showmaster is shutting down
3. [Vers] Showmaster's current version of Manager
4. [Proj] Title of the running project
5. [Addr] Current IP address
6. [Mask] Subnet mask
7. [Gway] IP Gateway address
8. [MacA] MAC address
9. [SerN] Serial Number

## LED Status Messages

Four LEDs give a quick overview of the main status of Medialon Showmaster.

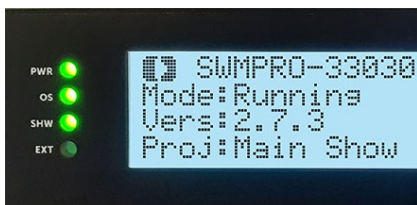

### PWR: Power LED

This LED lights green when power is present, regardless of whether Showmaster is powered on.

**OS: Showmaster Firmware LED**





















This LED indicates the current status of Medialon Showmaster software.

**SHW: Project LED**

This LED indicates the current status of the Medialon Showmaster Project.

**EXT**

Not used

Status	OS	SHW	EXT
Default State	OFF 	OFF 	OFF 
Showmaster Starting Up / Shutting Down	ON 	OFF 	OFF 
Showmaster Ready (OS)	ON 	OFF 	OFF 
Showmaster Project Starting	ON 	ON 	OFF 
Showmaster in Running Mode	ON 	ON 	OFF 
Showmaster in Programming Mode	ON 	Blink 	OFF 
IP address conflict detected	ON 	ON 	Blink 

**3.4.4 Rear Panel**

The figure below shows the rear panel of Medialon Showmaster Pro Mk 2.



- [USB 1]: Not used
- [USB 2]: Not used
- [LAN 1] RJ45 Ethernet LAN connector (10/100/1000 Base-T)
- [LAN 2] RJ45 Ethernet LAN connector (10/100/1000 Base-T)
- [DMX 1] DMX Port 1: Input / Output DMX512

- [DMX 2] DMX Port 2: Input / Output DMX512
- [MIDI In] MIDI Port: Input MIDI
- [MIDI Out] MIDI Port: Output MIDI
- [Timecode In] Timecode Port: Timecode Input
- [Timecode Out] Timecode Port: Timecode Output
- [Video Ref] BNC Port: Blackburst Video Reference Input
- [Serial 1] Serial Port 1: Serial RS232 port
- [Serial 2] Serial Port 2: Serial RS232 port
- [Serial 3] Serial Port 3: Serial RS232 port
- [Serial 4] Serial Port 4: Serial RS232 port
- [Serial 5] Serial Port 5: Serial RS232 port
- [Serial 6] Serial Port 6: Serial RS232 port
- [Serial 7] Serial Port 7: Serial RS232 port
- [Serial 8] Serial Port 8: Serial RS232 port
- [Relay Outputs] Digital Output Port: 16 Form C electro-mechanical 1A relays
- [Digital Inputs] Digital Input Port: 16 optically isolated inputs
- [POWER] Power Connector 12 V DC 5 A. [See Power section for details.](#)

## Digital Input/Output Port Wiring

### Digital Input Connector

Medialon Showmaster Pro has sixteen optically-isolated inputs that can accept either AC or DC signals and are not polarity sensitive. Input signals are rectified by photocoupler diodes and unused power gets dissipated through a 1.8 k $\Omega$  resistor in series. The inputs may be driven by either DC or AC sources of 3 to 31 volts (RMS with frequencies of 40 Hz to 10 kHz). Standard 12/24 volt AC control transformer outputs can be accepted as well. External resistors connected in series may be used to extend the input voltage range, however this will raise the input threshold range.

Isolated Inputs are connected to Showmaster Pro via a SubD 37 pin Male connector.

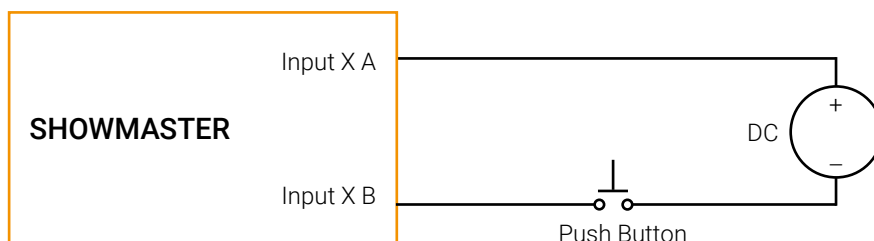

## Showmaster Overview

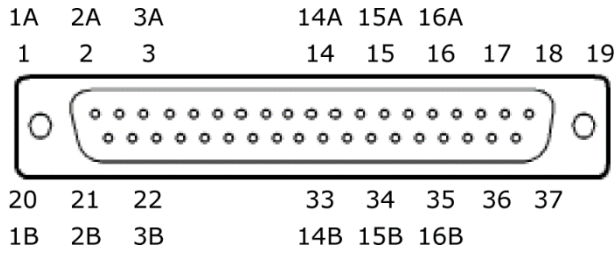

Signal	PIN #
Isolated Input 1A	1
Isolated Input 1B	20
Isolated Input 2A	2
Isolated Input 2B	21
Isolated Input 3A	3
Isolated Input 3B	22
Isolated Input 4A	4
Isolated Input 4B	23
Isolated Input 5A	5
Isolated Input 5B	24
Isolated Input 6A	6
Isolated Input 6B	25

Signal	PIN #
Isolated Input 7A	7
Isolated Input 7B	26
Isolated Input 8A	8
Isolated Input 8B	27
Isolated Input 9A	9
Isolated Input 9B	28
Isolated Input 10A	10
Isolated Input 10B	29
Isolated Input 11A	11
Isolated Input 11B	30
Isolated Input 12A	12
Isolated Input 12B	31

Signal	PIN #
Isolated Input 13A	13
Isolated Input 13B	32
Isolated Input 14A	14
Isolated Input 14B	33
Isolated Input 15A	15
Isolated Input 15B	34
Isolated Input 16A	16
Isolated Input 16B	35
No Connection	17
No Connection	36
No Connection	18
No Connection	19
No Connection	37

## Relay Output Connector

Medialon Showmaster V2 Pro's relay outputs are comprised of sixteen SPST electromechanical relays. All relays are de-energized at power-on.

Relay outputs are connected to Showmaster V2 via a SubD 37 pin Female connector. The wiring may be directly from signal sources or through our optional Breakout Box wiring terminal (SWM\_BO\_KIT). Pin assignments follow.

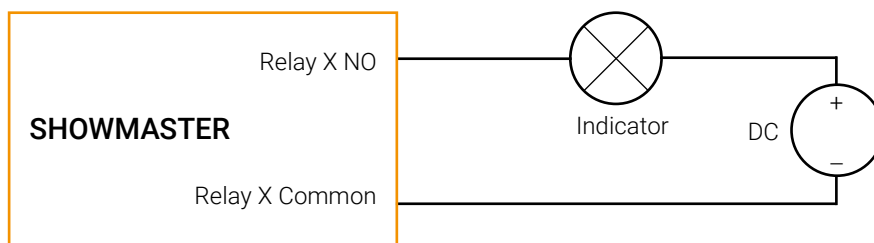

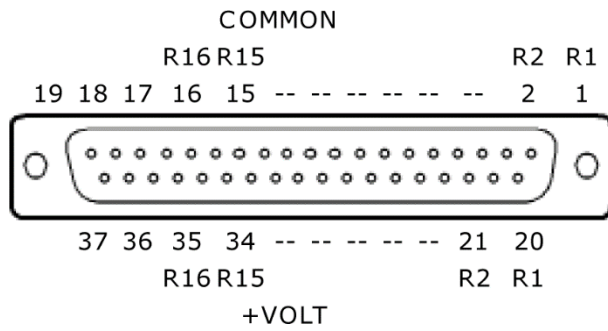

Signal	PIN #
Relay 1 (NO)	20
Relay 1 (Common)	1
Relay 2 (NO)	21
Relay 2 (Common)	2
Relay 3 (NO)	22
Relay 3 (Common)	3
Relay 4 (NO)	23
Relay 4 (Common)	4
Relay 5 (NO)	24
Relay 5 (Common)	5
Relay 6 (NO)	25
Relay 6 (Common)	6

Signal	PIN #
Relay 7 (NO)	26
Relay 7 (Common)	7
Relay 8 (NO)	27
Relay 8 (Common)	8
Relay 9 (NO)	28
Relay 9 (Common)	9
Relay 10 (NO)	29
Relay 10 (Common)	10
Relay 11 (NO)	30
Relay 11 (Common)	11
Relay 12 (NO)	31
Relay 12 (Common)	12

Signal	PIN #
Relay 13 (NO)	32
Relay 13 (Common)	13
Relay 14 (NO)	33
Relay 14 (Common)	14
Relay 15 (NO)	34
Relay 15 (Common)	15
Relay 16 (NO)	35
Relay 16 (Common)	16
No Connection	17
No Connection	18
No Connection	19
No Connection	36
No Connection	37

**i** When using Breakout boxes (SWM\_BO\_KIT), the maximum electrical specifications are 150 mA / 12 V DC per relay with a maximum of 2 A for the whole 16 relays.

## MIDI Connection

Medialon Showmaster Pro is provided with a MIDI input port and a MIDI output. It uses standard MIDI pinouts.

### Pin Connection

- 1 NC
- 2 NC
- 3 Cable shield (output only)
- 4 +5 V DC (source)
- 5 MIDI Data (sink)

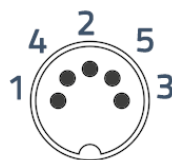

## DMX Connection

Medialon Showmaster Pro is provided with 2 DMX 512 ports that can be used for input or output (software configurable in the Resource Setup).

### Pin Connection

- | Pin | Connection |
|-----|------------|
| 1   | Ground     |
| 2   | Data -     |
| 3   | Data +     |
| 4   | NC         |
| 5   | NC         |



## Timecode Connection

Medialon Showmaster Pro is provided with 1 Timecode balanced input port and 1 Timecode balanced output port.

### Pin Connection

- | Pin | Connection   |
|-----|--------------|
| 1   | Cable shield |
| 2   | Signal +     |
| 3   | Signal -     |



## Serial Connection

Medialon Showmaster V2 Pro is provided with 8 serial ports.

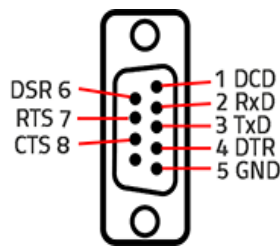

Showmaster Pro is configured with DTE serial ports. Use a crossover (null modem) cable when you want to connect to a computer.

### 3.4.5 Rack Mount

**WARNING** – The unit is intended to be rack-mounted as per applicable requirements so no imbalance of internal components is likely to occur. Adequate airflow clearance is to be provided so ambient temperature does not exceed the limit.

- Please refer to document: **M562 Medialon Safety Instructions** for installation, use and service.

## Installation

NOTE You need a #2 Phillips screwdriver for rack mount installation. Complete the following steps to mount devices in a rack:

- Remove the rack mount kit from the shipping carton. The kit contains two L-shaped mounting brackets and four sink-head screws.
- Using a Phillips screwdriver, attach the mounting brackets to the sides of the device using four sink-head screws.
- Using a Phillips screwdriver, mount the device in the rack using four rack-mounting screws.

## 3.4.6 Technical Specifications

### Network Connection

- Number: 2
- Connector: RJ45 female
- Interface: 10/100/1000 Mbps (1000 BaseT)
- *Protocol*: TCP/IP
- *Addressing*: Static IP or DHCP

### USB Connections

- Number: 2
- Connector: USB slave socket
- Interface: USB 2.0

### Serial Interfaces

- Number: 8
- Connector: 9-pin D-type Male
- Format: RS-232

### Digital Interfaces

Isolated Inputs:

- Number: 16
- Type: Non-polarized, optically isolated inputs (CMOS compatible)
- Voltage Range: 3 to 31 DC or AC RMS (40 – 10,000 Hz)
- Isolation: 500 V channel-to-ground or channel-to-channel

- Input Resistance: 1.8 k $\Omega$  in series with opto-coupler
- Filter Response Times: Rise Time = 4.7 mS / Fall Time = 4.7 mS
- Non-Filter Response Times: Rise Time = 10  $\mu$ S / Fall Time = 30  $\mu$ S
- Connector: Sub-D 37 – type Male

#### Relay Outputs:

- *Number*: 16 SPDT form C Relays
- *Contact Type*: Single crossbar; Ag with Au clad
- *Rated Load AC*: 0.5 A at 125 V AC (62.5 VA max.)
- *Rated Load DC*: 1 A at 24 V DC (30 W max.)
- Max. Switching Voltage: 125 V AC, 60 V DC
- \*Max. Switching Current: 1 A
- Contact Resistance: 100 m $\Omega$  max.
- *Contact Life*: 5 million operations min.
- Operating Time: 5 mS max.
- Release Time: 5 mS max.
- *Connector*: Sub-D 37 – type Female



When using Breakout boxes (SWM\_BO\_KIT), the maximum electrical specifications are 150 mA / 12 V DC per relay with a maximum of 2 A for the whole 16 relays.

#### Power Required:

- 5 V@ 30 mA typical (all relays off, add 30 mA per relay)
- 5 V@ 510 mA typical (all relays ON)

### DMX Interface

- *Number*: 2 DMX512 Input or Output
- *Connector*: XLR 5 pin – type Female

### TimeCode Interface

- *Number*: 1 Balanced Timecode Input (Female), 1 Balanced Timecode Output (Male)
- *Connector*: XLR 3 pin
- *Format*: SMPTE



## Video Reference Interface

- *Number:* 1 Blackburst
- *Connector:* Isolated BNC female, 75  $\Omega$ , Input level 0.65 Vpp to 2.0 Vpp (1.0 Vpp nominal, ntsc, pal).

## MIDI Interface

- *Number:* 1 MIDI Output / 1 MIDI Input
- *Connector:* MIDI DIN 5 pin – type Female

## Physical

- *Size Rack Mount (W × D × H):* 18.75 × 10.25 × 3.5" (476 × 260 × 89 mm)
- *Size Stand-alone (W × D × H):* 17.38 × 10.25 × 3.5" (441 × 260 × 89 mm)
- *Weight:* 11 lbs (5 kg)
- *Operating Temperature:* 32°F – 104°F (0°C – 40°C)
- *Storage Temperature:* –4°F – 185°F (–20°C – 85°C)
- *Operating Humidity:* 10 – 80% RH Non-condensing
- *Storage Humidity:* 5 – 90% RH Non-condensing
- *Operating Altitude:* sea level to 2000 metres.

## Power

- External Power Adapter EDACPOWER ELEC
- Model EA10683N-120
- AC Input 100-240 V – 2.0 A, 50-60 Hz
- DC Output 12 V DC 5 A
- Connector: DC-Jack

## Approvals

- FCC 47 CFR Part 15 Subpart B
- ICES-003 Canada
- EN 55032
- IEC 61000-3-2 and IEC 61000-3-3
- EN 55024
- IEC-61000-4-2 and IEC-61000-4-3 and IEC-61000-4-4 and IEC-61000-4-5 and IEC-61000-4-6 and IEC- 61000-4-11

- IEC/EN/UL 62368-1
- CSA C22.2#62368-1
- IEC 60950-1

### **Federal Communications Commission (FCC Statement)**

This equipment has been tested and found to comply with the limits for a class A digital device, pursuant to Part 15 of the FCC rules. These limits are designed to provide reasonable protection against harmful interference when the equipment is operated in a commercial environment. This equipment generates, uses, and can radiate radio frequency energy, and if not installed and used in accordance with the instruction manual, may cause harmful interference to radio communications. Operation of this equipment in a residential area may cause harmful interference, in which case the user will be responsible for correcting any interference at their own expense. Changes or modifications not expressly approved by the party responsible for compliance could void the user's authority to operate the equipment

FCC responsible:

7thSense Design Ltd  
4207 Vineland Rd.  
Suite M1  
Orlando, FL 32811  
USA

T: +1 407 505 5200

### **EMC notices**

EN55032/CISPR32 Class A MME (MultiMedia Equipment)

**Warning:** This equipment is compliant with Class A of CISPR 32. In a residential environment this equipment may cause radio interference.

GB/T 9254 Class A ITE (Information Technology Equipment)

**Warning:** This is a Class A product. In a domestic environment this product may cause radio interference in which case the user may be required to take adequate measures.

### **Accessories**

- *Included:* Mains cable, Rack Mount Brackets
- *Options:* SWM\_BO\_KIT Breakout Kit (DB-37 Cable, DIN-Mountable IO Wiring Terminal)

### **SWM\_BO Breakout Kit**

The SWM\_BO\_KIT Breakout Kit is a terminal block that can be used to break out Showmaster's digital I/O DB37 connectors to screw terminals for easy field termination. The Breakout Kit is

designed with both DB37 male and female connectors so it can be used with either the Digital Input or Relay port.



The SWM\_BO Breakout Kit ships with a RoHS compliant terminal block, a DB-37 Male-to-Female cable and two DIN-rail mounting clips.

When using Breakout boxes (SWM\_BO), the maximum electrical specifications are 150 ma / 12 V DC per relay with a maximum of 2 A for the whole 16 relays.

## 3.5 Showmaster Go Description

---

### 3.5.1 Contents of the Package

The Medialon Showmaster Go Package includes:

- Medialon Showmaster Go
- Power adaptor

### 3.5.2 Getting Started

Showmaster Go runs the full Medialon Manager V6 or V7 Lite or Pro software, and programming can be done directly on the hardware.



### 3.5.3 Front Panel

#### Power Button and LEDs

- 🔌 Press to power on Showmaster Go. The white ring light on the power button indicates the power state, as does the orange LED to the left of the power button. A blue LED behind the orange air filter indicates whether the Showmaster Go has power and remains on even when Showmaster Go is powered off.

## Ports

1 × USB 2.0 (Type-A) and 1 × USB 3.1 (Type-C)

## Air Filter

Remove the door and filter, clean or replace the foam tucking it under the left-side screw mount and noting the orientation of the filter. Re-engage the door on the right side, and secure with the screw.

## 3.5.4 Rear Panel

The image below shows the rear panel of Medialon Showmaster Go.



- Kingston safe lock
- 12-19 VDC power inlet with cable inlet clip
- 4 × DisplayPort™ 1.2
- 3 × opto-isolated (0-3.5 V TTL)
- 2 × RJ45 10/100/1000 base-T Ethernet
- 2 × USB 2.0 (Type-A)

## Dual NIC ports

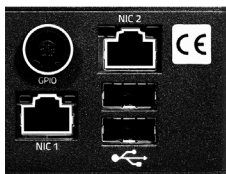

The RJ45 port labelled 'NIC 1' is factory-set to be the Dante network audio output, using DHCP and 'NIC 2' is reserved for show control; NIC 2 is also factory-set to DHCP.

## Digital Input/Output Port Wiring

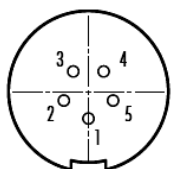

5-pin Binder 420 socket, pin 5 = Vcc

Showmaster Go GPIO cables with fly lead are available from Medialon.

### 3.5.5 Mounting

The Showmaster Go can be mounted singly or in multiples up to three per rack unit. The available mounting options are VESA, an anti-shock mounting frame, and a rack mounting tray. All are available options from Medialon.

When mounting the Showmaster Go, do not block any server air vents, and ensure the ambient temperature around the server is compatible with the environmental characteristics stated.

Particularly when mounted in a rack cabinet with front or rear doors, the ambient temperature around the server may be higher than the ambient room temperature.

Showmaster Go can be mounted vertically using the optional VESA mounting plate or anti-shock frame, but care must be taken that hot air from the rear panel is not drawn back in at the front. Do not mount with the front panel uppermost.

- See document **M555 Mounting the Medialon Showmaster Go** for full details with illustrations.

### 3.5.6 Technical Specifications

USB ports	3 × USB 2.0 (Type-A), 1 × USB 3.1 (Type-C)
Power connection	12-19 VDC, 60 watts max; DC power inlet clip
Ethernet	2 × 10/100/1000 base-T
Video output	4 × DisplayPort™ 1.2
GPIO	3 × opto-isolated (0-3.5 V TTL)
Mounting options Kingston Safe Lock	VESA mount; rackmount tray (takes 1-3 units); anti-shock frame;
Dimensions (W × L × H)	145 mm × 152 mm × 44 mm (5-3/4" × 6" × 1-3/4")
Weight	1.4 kg (3 lbs)

Technical specifications are subject to change without prior notice. Please check <https://7thSense.one> for the latest information.

## Approvals and Environmental Information

### Federal Communications Commission (FCC Statement)

This device complies with Part 15 of the FCC Rules. Operation is subject to the following two conditions: (1) this device may not cause harmful interference, and (2) this device must accept any interference received, including interference that may cause undesired operation.

Note: This equipment has been tested and found to comply with the limits for a Class A digital device, pursuant to part 15 of the FCC Rules. These limits are designed to provide reasonable protection against harmful interference when the equipment is operated in a commercial environment. This equipment generates, uses, and can radiate radio frequency energy and, if not

installed and used in accordance with this user guide, may cause harmful interference to radio communications. Operation of this equipment in a residential area is likely to cause harmful interference in which case the user will be required to correct the interference at their own expense.

### European Union

This is a Class A product. In a domestic environment, this product may cause radio interference, in which case the user may be required to take adequate measures.

FCC and EU responsible:

7thSense Design Ltd  
4207 Vineland Rd.  
Suite M1  
Orlando, FL 32811  
USA

T: +1 407 505 5200

Please refer to document **M557 Showmaster Go Hardware User Guide** supplied with your unit.

## 3.5.7 Environment

### General

Showmaster Go is intended for use in a commercial (not domestic) environment and should be operated in a clean, dust free area (e.g. a server room).

The unit is intended for operation in benign environments; that is, not subject to corrosive or explosive atmospheres, moisture or flammable gases. The unit is non-protected against ingress of liquid (IPx0). The unit is not designed to be subject to excessive mechanical shock or vibration. For environments with some movement and vibration, an anti-shock frame mount is available for single units.



Only used at altitude  
not exceeding 2000 m



Only used in not-tropical  
climate regions

### Thermal

Do not block any of the unit's air vents and ensure the ambient temperature around the unit is compatible with the environmental characteristics stated on the back page of this manual.

Particularly when mounted in a rack cabinet with front or rear doors the ambient temperature around the unit may be higher than the ambient room temperature.



Showmaster Go can be mounted vertically using the optional VESA mounting plate, but care must be taken that hot air from the rear panel is not drawn back in at the front. Do not mount with the front panel uppermost.

## Electrical

Before connecting mains power to the unit's power supply unit (PSU), ensure the electricity supply is compatible with the electrical ratings shown here and on the power supply product label.

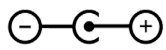

The power supply unit is connected to, and disconnected from, the mains supply with an IEC 60320 power connector.

## 3.5.8 Maintenance

### Air Filter

It is important to remove and clean or replace the filter periodically to avoid overheating. Showmaster Go units are supplied with one spare filter pad, others can be provided by your supplier. Showmaster Go should not be run without filters, since accumulations of dust inside the unit can affect performance.

### Cleaning

External casing and the front panel should be carefully wiped with a soft cloth and antistatic solution.

### Showmaster Go internal maintenance

Showmaster Go contains no user-serviceable parts. For CMOS battery replacement please contact your supplier for further instructions.



**Warning:** Do not operate the unit with any covers removed as the air flow through the unit may be compromised leading to overheating.

Any alterations to the product's specification, including additional/alternative components, BIOS changes, overclocking, etc., may invalidate the warranty or impact the unit's performance. Additionally, such changes or modifications could cause equipment no longer to comply with the relevant EMC regulations, and void the user's authority to operate the equipment. If in doubt, please contact your supplier.

## 3.6 Disposal Information: All Showmaster Devices

---

### Waste Electrical and Electronic Equipment



**Dispose of the equipment and any components in accordance with all local and national safety and environmental requirements.**



This symbol on the product indicates that, under the European Directive 2012/19/EU governing waste from electrical and electronic equipment, this product must not be disposed of with other municipal waste. Please dispose of your waste equipment by handing it over to a designated collection point for the recycling of waste electrical and electronic equipment. To prevent possible harm to the environment or human health from uncontrolled

waste disposal, please separate these items from other types of waste and recycle them responsibly to promote the sustainable reuse of material resources. For more information about recycling of this product, please contact your local city office or your municipal waste disposal service.

### Disposal of batteries in the product



This product contains batteries covered by the European Directive which must be collected and disposed of separately from municipal waste. If the battery contains more than the specified values of lead (Pb), mercury (Hg) or cadmium (Cd), these chemical symbols will appear below the crossed-out wheeled bin symbol. By participating in separate collection of batteries, you will help to ensure proper disposal and to prevent potential negative effects on the environment and human health.

## RoHS compliance

### Turkey RoHS compliance



Türkiye Cumhuriyeti: AEEE Yönetmeliğine Uygundur [Republic of Türkiye: In conformity with the WEEE Regulation]

### China RoHS Hazardous Substance Table

零件项目(名称) Component Name	有毒有害物质或元素 Hazardous Substances or Elements					
	铅 (Pb)	汞 (Hg)	镉 (Cd)	六价铬 (Cr6+)	多溴联苯 (PBB)	多溴二苯醚 (PBDE)
印制电路配件 Printed Circuit Assemblies	X	O	O	O	O	O
螺帽,螺钉(栓),螺旋(钉),垫圈,紧固件 Nuts, bolts, screws, washers, Fasteners	X	O	O	O	O	O
内部线路 Internal wiring	X	O	O	O	O	O
风扇 Fan	X	O	O	O	O	O
电源供应器 Power Supply Unit	X	O	O	O	O	O
固态硬盘 SSD	X	O	O	O	O	O

这个表被制备按照规定SJ/T 11364  
This table is prepared in accordance with the provisions of SJ/T 11364.

O: 表示该有毒有害物质在该部件所有均质材料中的含量均在 GB/T 26572 标准规定的限量要求以下。  
O: Indicates that this hazardous substance contained in all of the homogeneous materials for this part is below the limit requirement of GB/T 26572.

X: 表示该有毒有害物质至少在该部件的某一均质材料中的含量超出 GB/T 26572 标准规定的限量要求。  
X: Indicates that this hazardous substance contained in at least one of the homogeneous materials used for this part is above the limit requirement in GB/T 26572.



# 4 Showmaster Maintenance

---

In this section, you will learn how to maintain your Medialon Showmaster.

## 4.1 Showmaster Troubleshooting

---

This section helps resolve problems you may encounter while using Medialon Showmaster.

Common Problems and Solutions:

Problem	Check These Items
Does not turn on	Check that the power cable is plugged in. Check that the rear power switch is On.
Showmaster Status indicator (LED OS) does not turn on	Contact your dealer; this Showmaster may need to return to the factory.
Showmaster Status indicator (LED OS) lights red	Contact your dealer, this Showmaster may need to return to the factory.
Project Status indicator (LED SHW) does not turn on	Check project presence
Project Status indicator (LED SHW) lights red	Check the project Delete the current project.
No DMX signal	Check that the DMX cable is plugged in. Check DMX sending
No MIDI signal	Check that the MIDI cable is plugged in (for Showmaster V2 ST) Check MIDI sending/receiving
No Serial communication	Check that the Serial cable is plugged in. Check the Serial pinout of the connected device. Check Serial sending/receiving
Digital Relay Output not switching	Check that the Relay cable is plugged in. Check Relay commands
No Digital Input contact detected	Check that the Input cable is plugged in. Check Input receiving
No Network connection	Check that the network cable is plugged in. Check the activity LED on network socket. Check the Showmaster's IP configuration
Front panel displays 'License...'	Contact your dealer; this Showmaster may need to return to the factory.
No text on front panel display	Contact your dealer, this Showmaster may need to return to the factory.
Not responding to Front panel controls	Contact your dealer, this Showmaster may need to return to the factory.

# Contact Us

---

Find more on our website <https://7thSense.one> and on social media. For documentation, visit <https://portal.7thSense.one>



or contact our support team at [support@7thSense.one](mailto:support@7thSense.one)





E: [info@7thsense.one](mailto:info@7thsense.one)

W: [7thsense.one](http://7thsense.one)

**7thSense Design Ltd**

2 The Courtyard Shoreham Road  
Upper Beeding  
Steyning  
West Sussex  
BN44 3TN  
UK

T: +44 (0) 1903 812299

**7thSense LLC, Michigan**

332 E Lincoln Ave  
Suite 100  
Royal Oak, MI 48067  
USA

T: +1 248 599 2717

**7thSense LLC, Orlando**

4207 Vineland Rd  
Suite M1  
Orlando, FL 32811  
USA

T: +1 407 505 5200

---